

○ TECHNICAL ARTICLE

SHRINKING TO THE CHALLENGE - HOW TO DESIGN A SMALLER, MORE EFFICIENT AC-DC POWER SUPPLY

In an odd way power supplies are like insurance policies - you know you need one but it's not something you really want to think about. How your next electronic system functions is much more interesting, the power supply is a necessary evil to make it work. In another way, the analogy falls down. Insurance policies invariably increase in price, while power supplies have become smaller, more efficient and lower cost over the last couple of decades. This trend towards smaller power supplies, that leave more room in the system for added functionality and processing power, is set to continue. Furthermore, these power supplies must fit the standard formats that are already in use to avoid system re-design costs.

In the case of AC/DC power units, it is not dramatic technology breakthroughs that drive the trend, it is good engineering and the inventiveness to combine the best of a whole range of techniques and technologies that separate a really innovative power supply from an average one. This article looks at AC/DC power supply design in the popular 100W to 200W range. It considers a combination of design approaches that can be brought together to minimise the size and cost of the power unit, whilst maximising efficiency and application flexibility.

Let's start by defining some typical design goals. The power supply should be as small as possible to save space or leave room for added system functions. It should make minimal contribution to the waste heat in the system. In practice, it is microprocessors that now create most system heating but it is still important that power supplies are designed for high efficiency; smaller heat sinks can then be used to save space. For a 100 W to 200 W power supply, efficiency goals of 90% are not unrealistic. A 1% efficiency improvement represents 10% less heat dissipation at the upper end of the range and this can make a significant difference to the degree of cooling needed for the power supply. Cost, of course, is an ever-present consideration, both in terms of bill of materials and manufacturing complexity. Keeping the design as simple as possible is an important consideration in this respect. Finally, functionality should not be compromised. Control and alarm signals, current sharing with similar units, and the ability of the power supply to maintain its performance over a wide range of AC input conditions are all important.

Looking at the main stages within an AC/DC power supply shown in Figure 1, here are some proven ways in which size and cost can be minimised without compromising performance or functionality.

1. Input filter. A two-stage filter design using high permeability cores will minimise size while providing high common mode and differential noise reduction. Stacking some components vertically can save board space and improve cooling.
2. Power factor correction circuit (PFC). The use of silicon carbide diodes has become economically feasible in the last 2 years as component prices have fallen. Their reverse current characteristics mean that they don't require a snubber circuit, saving on 5 or 6 components. Furthermore, they contribute to a 1% typical efficiency boost. Using a stepped gap inductor provides high inductance at high input line and supports maximum flux density at low line. Using continuous conduction mode (CCM) operation throughout the input range keeps the peak switching current and input filter requirements to a minimum.
3. Main converter. Here, a resonant topology can virtually eliminate switching losses. This not only improves power supply efficiency but also enables smaller heat sinks to be used. In fact, compact ceramic heatsinks can sometimes be used for power transistors, rather than metal ones. Their advantages include a reduction in noise and consequently simplified filtering. This is because the heatsinks do not have capacitive coupling with the drain connections of the switching MOSFETS. In addition, smaller creepage distances, compared with those needed for metal heatsinks, can be used. This gives further savings in board space.
4. Output rectifier. Opt for synchronous rectification here, using switched MOSFETS rather than output rectifier diodes. This improves efficiency through a significant reduction in power dissipation. For example, at 20 Amps a diode with 0.5 V forward voltage gives a power dissipation of 10 W. Using a MOSFET with an 'ON' resistance of, say, 14 mΩ at +100 °C dissipates just 5.6 W – a 44% improvement. Once again, ceramic substrates can replace conventional heatsinks.
5. Control circuit. Semiconductor manufacturers have been developing increasingly integrated control circuits for power supplies in recent times. This means savings in component count, manufacturing costs and board space, even where the integrated circuits themselves may be more expensive than a discrete component approach. One example is the IR1150 – a PFC chip that operates as a one-cycle control (OCC) device, which allows major reductions in component count without reducing power system performance. Similar, application-specific chips can provide main converter voltage control plus over-current protection, over-voltage protection and over-temperature protection. They can also control the output rectifier switching. Other desirable control options for increased application flexibility include power sharing with synchronous monotonic start-up, an inhibit circuit to shut down the power supply via logic control, a 'power good' signal, and the control functionality needed for a standby converter. The standby converter provides an independent 5V output whenever AC power is present.

Figure 1

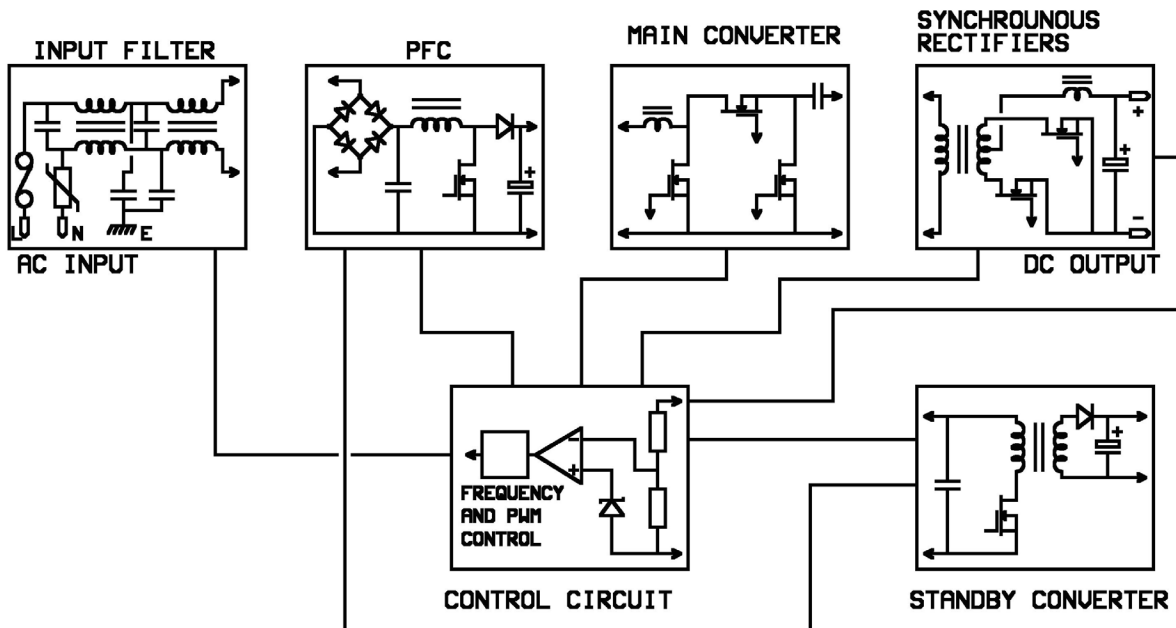

Today's best-in-class AC/DC switchers are typified by XP Power's EMA212 power supply, shown in Figure 1. Using some of the techniques described above, this packs 212.5 W output from a 3 x 5 inch footprint with a maximum height of 1.34 inches. That's a power density of 10.55 W per cubic inch in an industry standard footprint that fits within a 1U high enclosure. It delivers 200 W from its main 12 V or 48 V output, plus 12 V at 1 A for driving fans and a 5 V standby output. The unit needs just 12 CFM of forced-air cooling, which is easily achievable using standard 40 x 40 mm fans. Forced-air cooling is now the norm in many communications systems and 12 CFM is easily achievable without complex mechanical arrangements. Finally, it achieves an efficiency of 91% at full rated load.

The possibilities for improvements in AC/DC power supply design will continue to be driven largely by improvements in semiconductor performance and functionality. Better magnetic and passive components also have a role to play, but here progress is more evolutionary than revolutionary. The best power supplies are developed from a deep understanding of the latest proven component technologies, plus a determination to explore how these technologies can be combined in new and innovative ways to achieve ever more challenging design objectives.