

## ○ TECHNICAL ARTICLE

# OVERCOMING PATIENT LEAKAGE CURRENT ISSUES

XP's Dante De Guzman explains patient leakage current for medical power supplies and describes several ways of reducing and controlling this leakage current for the most stringent medical applications.

IEC 60601 is the generally accepted standard for medical electrical and electronic equipment, required for the commercialization of this type of equipment in many countries. To guard against electric shock, the specification defines maximum leakage currents for equipment with an applied part, that is, a part of the equipment that comes into contact with the patient under normal operating conditions.

There are four types of applied part as defined in the standard. Type B (body) means applied parts that are not normally conductive and can be immediately released from the patient, including everything from MRI scanners to hospital beds and lighting. Type B is the least stringent classification. Type BF (body floating) and CF (cardiac floating) are floating with respect to earth. Type BF parts have conductive contact with the patient, or medium to long term contact with the patient, like ultrasound equipment and blood pressure monitors. Type CF parts have the most stringent classification as they are parts that may come into direct contact with the heart, like dialysis machines. There are also three types of leakage current, each with their own defined limit in the standard: earth leakage current, enclosure leakage current, patient leakage current and patient auxiliary current. The leakage current type that is typically the hardest to meet is the patient leakage current, that is, the current flowing from the applied part via the patient to earth as a result of an unintended voltage from an external source on the patient. For the third edition of the standard, the limit is 100uA for B & BF and 10  $\mu$ A for CF. In power supplies, the patient leakage current is defined as the amount of leakage current flowing from the output through a 1 k $\Omega$  impedance to ground (which represents the patient). This is directly proportional to amount of capacitance between the mains and the output (input to output capacitance), which is dependent on two things: the interwinding capacitance of the transformer and the Y-capacitors bridging the primary side to the secondary side (bridging capacitors). Reducing the input to output capacitance is therefore desirable, but it's not possible to remove it entirely because it's required for patient safety by the standard.

### Input to Output Capacitance

Let's consider the input to output capacitance of a typical medical power supply. Figure 1 is a simple representation of such a device, with a leakage current path shown by the dotted line. The capacitance between the primary side and the secondary side of the transformer comprises the bridging capacitance (C4) and the transformer's interwinding capacitance. If C4 increases, the impedance of this current path decreases; if the impedance decreases, more current will flow through point G2. This current constitutes the patient leakage current. Note that C1 and C3 also create a path for current leakage – this is the earth leakage current rather than the patient leakage current. Figure 2 is a capacitance model of figure 1. The patient leakage current,  $I_{leakage}$ , is calculated as  $2 \cdot \pi \cdot f \cdot C4 \cdot V_{mains}$ . That is, the patient leakage current is directly proportional to the bridging capacitance. Popular techniques for reducing the patient leakage current therefore focus on reducing the input to output capacitance of the power supply. Probably the most common method of doing this is to add an additional DC-DC converter between the power supply and the applied part. This adds an extra layer of isolation as shown in Figure 3.

The dominant path for the current of the new system is now through C4 and C5, the interwinding capacitances of both transformers. The new patient leakage current is calculated as  $I_{leakage} = 2 \cdot \pi \cdot f \cdot C4 \text{ and } C5 \text{ in series} \cdot V_{mains}$  (as shown in the capacitance model in Figure 4) and is greatly reduced overall. As an example, recent work on a customer's medical system by XP Power reduced an AC-DC power supply's patient leakage current from 11 $\mu$ A to 6 $\mu$ A by adding an additional DC-DC converter as described above. Although this is an easy way to reduce the output capacitance, and therefore the patient leakage current, it does have its downsides. Adding another DC-DC converter to the system is always going to add cost and complexity, as well as increase the footprint of the power subsystem.

### Other Options

An alternative approach taken by XP is to work with the customer to reduce the leakage current of the AC-DC power supply, to try to avoid having to use an additional DC-DC converter. There are two options – either a completely custom power supply can be built, or more commonly, a standard medical power supply can be modified to reduce its leakage current.

The problem with reducing the leakage current of the AC-DC power supply is that because this is dependent on reducing the input to output capacitance, it can have major ramifications for the power supply's EMI (electromagnetic interference) performance, which is also tightly specified for medical applications. When designing a custom power supply, the task is approached with the trade-off between leakage current and EMI in mind, and can be solved by such things as optimizing the shielding in the transformer, for example.

A more popular solution than a full custom power supply is to modify a standard medical power supply to meet the requirements. Working with customers in real-world applications, XP Power has successfully modified standard medical power supplies to meet BF/CF leakage current requirements, that is, its patient leakage current is less than 10 $\mu$ A (overall compliance will depend on leakage currents from the rest of the system too). Such projects can be based on XP's GCS or ECM60 series, since these meet the isolation requirements of IEC60601-1. Modified versions of the GCS series' LLC topology can meet CF requirements in a 3x5" footprint, while modified ECM60 series power supplies have a 2x4" footprint and feature universal 90 to 264Vac input, while complying to EMI class B emissions. Modified power supplies from both of these series have demonstrated patient leakage currents below 10uA at 264 Vac/60 Hz.

A typical way to modify a standard power supply to reduce its input to output capacitance would be to reduce the value of any Y capacitors (bridging capacitors). However, it's not as straightforward as that for every power supply. Aside from the EMI concerns mentioned earlier, even removing the bridging capacitors completely might not be enough to reduce the patient leakage current to below 10  $\mu$ A – the interwinding capacitance is an inherent property of the transformer and cannot be modified, so if that's not low enough to start with, it might not be possible to reduce the output capacitance enough to meet the requirements. Other non-modifiable components like opto-isolators that cross between the primary side and secondary side can add to the output capacitance too. Well-designed power supplies like XP's feature low capacitance in these parts as standard. In summary, medical power supplies must meet stringent patient safety standards, and patient leakage current is often the hardest part of the standard to meet.

This leakage current is directly proportional to the input to output capacitance of the power supply, but reducing this capacitance is not always easy because of EMI concerns. Adding a DC-DC converter as an extra layer of isolation is one solution, though it may be costly. Custom power design is a feasible but unpopular option. Alternatively, XP Power works with customers to modify its standard medical power supplies to meet the most stringent patient leakage current requirements, which may be the most cost-effective option.

**Reducing the capacitance**

Figure 1

A simplified power supply. A simple representation of a medical power supply. In the absence of any bridging capacitors, the dominant path for the patient leakage current is through the transformer (marked by dotted line).

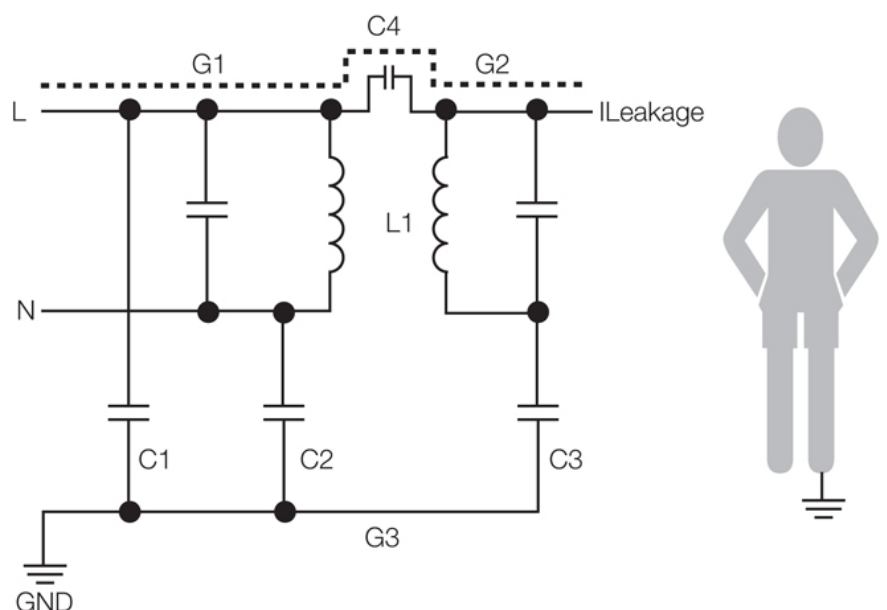

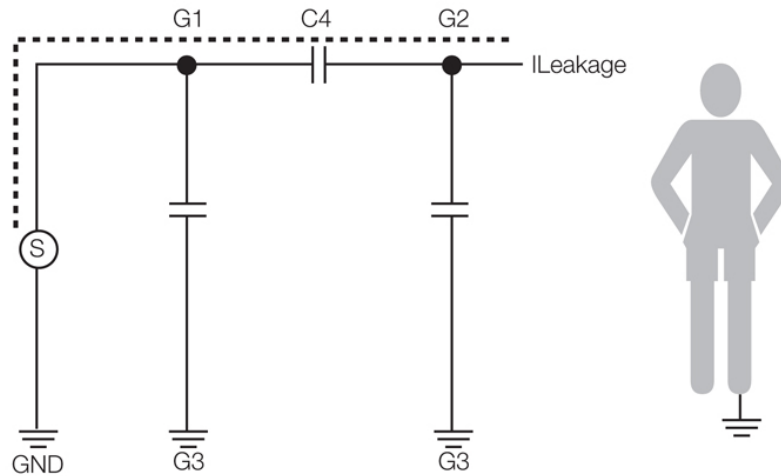

Figure 2 – PSU capacitance model from Figure 1. A capacitance model of the power supply in figure 1. The patient leakage current is directly proportional to C4.

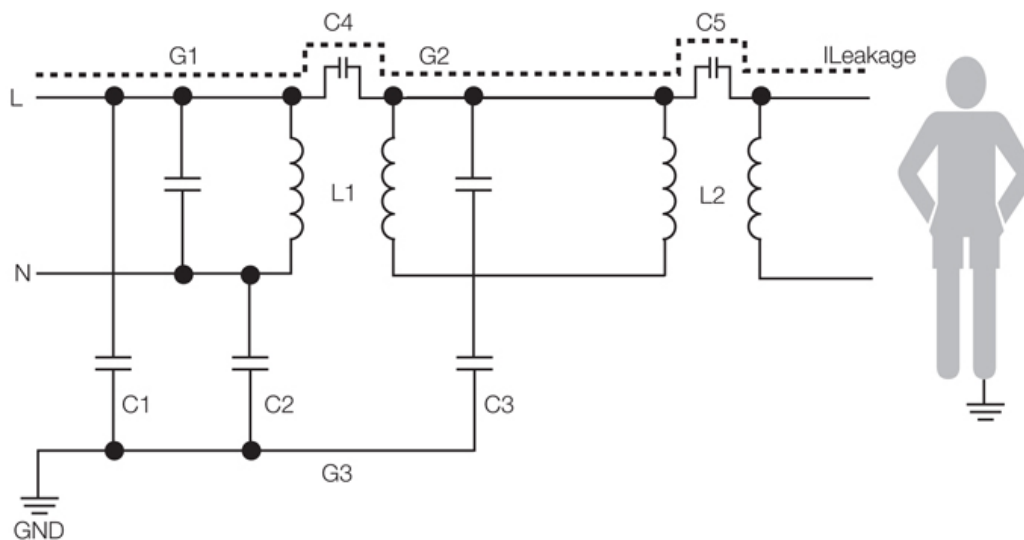

Figure 3 – PSU plus DC-DC converter. A common way to reduce the output capacitance, and therefore the patient leakage current, is to add a DC-DC converter to the output.

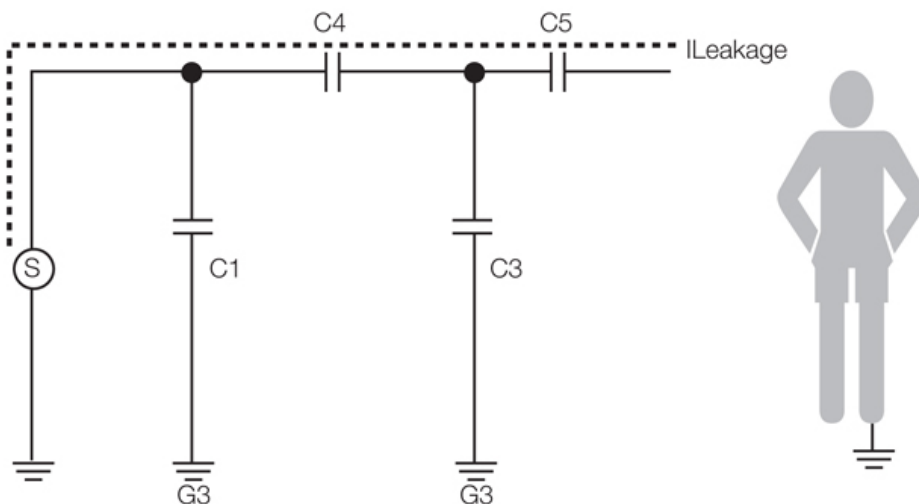

Figure 4 – Capacitance model for Figure 3. The capacitance model after the DC-DC converter is added shows the output capacitance is reduced to within acceptable levels.